

## **VGW QUATER-TURN WORM GEARBOX FOR MANUAL APPLICATION**

The VGWM Series quarter-turn worm gearbox has been designed for the operation of ball, butterfly and plug valves as well as power and process dampers.

### **APPLICATION**

The VGWM are ideally suited for applications in Oil & Gas, Chemical, Power, Water and HVAC industries and for most general industrial applications. They can be operated manually with Handwheels or motorized with Electrical Actuators using the various sizes and ratios for smooth operation.

### **FEATURES**

- Torque Range from 300 Nm to 720,000 Nm
- Totally enclosed gearing
- Ductile Housing
- Roller Bearing supporting input shaft
- End stop ranges from 0° to 90° (±10° Adjustable)
- Comprehensive gears ratios combined with a selection of auxiliary input spur gear reducers
- Self-Locking
- High quality corrosion protection
- Valve Connection: ISO5211
- Worm Gear: Ductile iron, Class 80-55-06 or Aluminum bronze, B148-C95800
- Temperature -40°C to +120°C

### **OPTIONS**

- Low temperature -60°C to +120°C
- High temperature -30°C to + 160°C
- Enclosure Protection IP68
- Many other options, such as padlock, painting color, Output Flange, auxiliary reducer, etc.

## PART LIST & MATERIAL

No.	Description	Material	BS	ASTM	Remark
1	Indicator Plate	Steel	BS970 045M10 or 606M36t	AISI/SAE 1010 or 4340	Standard
2	Housing	Ductile Iron	BS1563 EN-GJL-450-10	ASTM A536 65-45-12	
3	Cover	Ductile Iron	BS1563 EN-GJL-450-10	ASTM A536 65-45-12	
4	Worm	Steel	BS970 045M10 or 606M36t	AISI/SAE 1010 or 4340	
5	Worm Gear	Ductile Iron	BS1563 EN-GJS-700-2	ASTM A536 100-70-03	
6	Worm Gear Sleeve	Steel	BS970 070M55	AISI/SAE 1055	
7	Stem Bush	Steel	BS970 070M55	AISI/SAE 1055	
8	End Cover	Ductile Iron	BS1563 EN-GJL-450-10	ASTM A536 65-45-12	
9	Shaft Base	Ductile Iron	BS1563 EN-GJL-450-10	ASTM A536 65-45-12	
10	O Ring	NB Rubber	NBR	NBR	
11	R Housing	Ductile Iron	BS1563 EN-GJL-450-10	ASTM A536 65-45-12	
12	Spur Gear	Steel	BS970 817M40T	AISI/SAE 4340	
OP-1	Hand Wheel	Steel Pipe	BS1387	A182	Option
OP-2	Washer	Stainless Steel	BSEN10088-1-95	ASTM A276-96	
OP-3	HEX. Bolts	Stainless Steel	BSEN10088-1-95	ASTM A276-96	

## GEARBOX SECTION VIEW

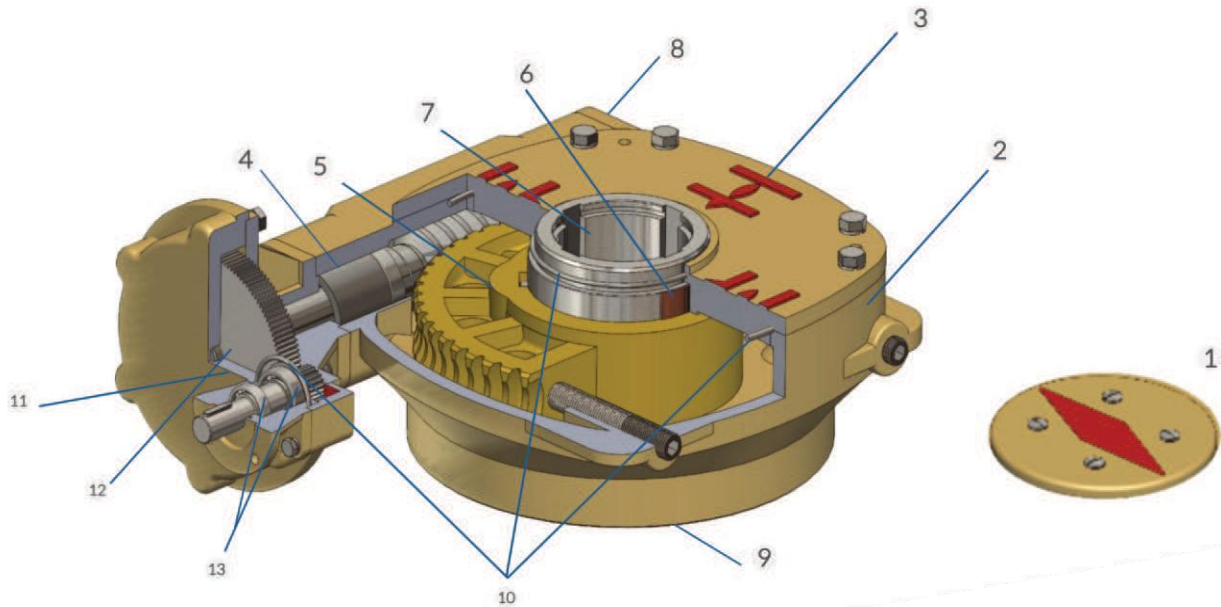



**SIZING DATA**

Model	Ratio				Type	MA				Input Flange	Output Flange		Output Torque Nm	Stem Size mm	Stem Height mm	Weight kg
											Std	Option				
VGW50	51				B1	15.3				F07/F10	F10	F07	300	35	68	9
VGW63	51				B1	15.3				F10	F12	F10	1,200	52	76	14
VGW80	53	40			B1	15.9	12			F10	F14	F12	2,500	70	83	18
VGW80R	92	106	156	221	A2	27.6	31.8	46.8	66.3	F10/F14						30*
VGW85	75				B1	22.5				F10/F14	F14	F12/F16	3,250	70	83	20
VGW85R	106	130	150	203	A2	31.8	39	45	60.9	F10/F14						32
	220	312				66	94									
VGW100	60	60	74		B1	18	15	22.2		F10/F14	F16	F14	5,850	85	120	41
VGW100R	85	10	120	15	A2	25.5	31.2	36	45	F10/F14						53
	176	250	312			52.8	75	93.6								63
	378					113.4										73
	426	492	585			127.8	147.6	175.5								
VGW125	60	70			B1	18	21			F14/F16	F25	F16	13,000	100	130	63
VGW125R	85	105	120	150	A2	25.5	31.5	36	45	F10/F14						73
	176	250	312			52.8	75	93								83
	378					113.4										93
	426	492	585			127.8	147.6	175.5								
VGW160	60	70			B1	18	21			F14/F16	F30	F25	16,000	130	150	83
VGW160R	90	106	120	154	A2	27	31.8	36	46	F10/F14						93
	190	240	310	378		57	72	93	113.4							101
	426	492	585	683		127.8	14.6	175.5	205							
VGW165	60	70			B1	18	21			F14/F16	F30	F25/F35	24,000	130	150	83
VGW165R	90	106	120	154	A2	27	31.8	36	46	F10/F14						93
	190	240	310	378		57	72	93	113.4							101
	426	492	585	683		127.8	14.6	175.5	205							
VGW195	55				B1	16.5				F16/F25	F35	F25/F30	34,000	160	165	196
VGW195R	83	92	110		A2	249	27.6	33		F10/F16/F25						208
	145	173	220	284		43.5	51.9	66	85.2							
	346	390	451	536		103.8	17	135.3	160.8							
	589	644	704	781		16	193.2	211.2	234.3							
	880					264										





**SIZING DATA continued**

Model	Ratio				Type	MA				Input Flange	Output Flange		Output Torque Nm	Stem Size mm	Stem Height mm	Weight kg
											Std	Option				
VGW200	55				B1	16.5				F16/F25						196
VGW200R	83	92	110		A2	249	27.6	33		F16/F25	F35	F25/F30	45,000	160	165	208
	145	173	220	284		43.5	51.9	66	85.2	F10/F16/F25						
	346	390	451	536		103.8	17	135.3	160.8							
	589	644	704	781		16	193.2	211.2	234.3							
	880	1015				264	304.5									
VGW250	55				B1	16.5				F16						229
VGW250R	83	92	110	132	A2	24.9	27.6	33	39.6	F14/F16/F25	F40	F30/F35	58,500	170	210	310
	174	220	284			52.2	66	85.2								
	372	407	443	516		111.6	122.1	132.9	154.8	F10/F14						
	566	687	770	880		169.8	206.1	231	264							
	1020					290.7				F10/F14						330
VGW255	55				B1	16.5				F16						229
VGW255R	83	92	110	132	A2	24.9	27.6	33	39.6	F14/F16/F25	F40	F30/F35	67,500	170	210	310
	174	220	284			52.2	66	85.2								
	372	407	443	516		111.6	122.1	132.9	154.8	F10/F14						
	566	687	770	880		169.8	206.1	231	264							
	1020					290.7				F10/F14						330
VGW310	65				B1											622
VGW310R	147	205	260		A2	44.1	61.5	78		F16/F25	F40	F35/F40	95,000	230	260	672
	325	390	474		A2	97.5	117	142.2								
	520	611	669	812	A2	156	183.3	200.7	243.6	F14						726
	910					273										
	1033	1273	1478	1612		294.4	362.8	421.2	459.4	F14						885
	1870	2060	2129	2254	A2	533	587.1	606.8	642.4	F10/F14						
	2413	2607				687.7	743									
VGW315	65				B1											622
VGW315R	147	205	260		A2	44.1	61.5	78		F16/F25	F40	F35/F40	116,000	230	260	672
	325	390	474		A2	97.5	117	142.2								
	520	611	669	812	A2	156	183.3	200.7	243.6	F14						726
	910					273										
	1033	1273	1478	1612		294.4	362.8	421.2	459.4	F14						885
	1870	2060	2129	2254	A2	533	587.1	606.8	642.4	F10/F14						
	2413	2607				687.7	743									





**SIZING DATA continued**

Model	Ratio				Type	MA				Input Flange	Output Flange		Output Torque Nm	Stem Size mm	Stem Height mm	Weight kg
											Std	Option				
VGW350	59				B1											795*
VGW350R	186	236			A2	55.8	70.8			F25	F40	F35/F48	130,000	230	260	897*
	25	354	430			88.5	106.2	129								
	937	1187	1463	1699	A2	267	338.3	417	484.2	F14/F16						
	1870	1932	2046	2190		533	550.6	583.1	624.2							
	2367	3009	3303			674.6	857	941		F14						
											F60					1047
VGW400	70				B1											863*
VGW400R	1112	1146	1213	1370	A2	316.9	326.6	345.7	390.5	F16	F40	F48/F60	150,000	255	300	967
	1592	1736	1810	2016		453.7	494.8	515.9	574.6	F14						
	2293	2427	2600	2808		653.5	691.7	741	800.3							
	2958	3130	3290	3570	843	892.1	937.7	1017.5								
	3620				1032											
VGW450	70				B1											863*
VGW450R	1112	1146	1213	1370	A2	316.9	326.6	345.7	390.5	F16	F40	F48/F60	208,000	255	300	967
	1592	1736	1810	2016		453.7	494.8	515.9	574.6	F14						
	2293	2427	2600	2808		653.5	691.7	741	800.3							
	2958	3130	3290	3570	843	892.1	937.7	1017.5								
	3620				1032											
VGW480	62				B1											
VGW480R	1075	1214	1410	1538	A2	306.4	346	401.9	438.3	F14/F16	F40	F48/F60	234,000	255		1025
	1604	1785	2030	2150		457.1	508.7	578.6	612.8							
	2303	2487	2620	2773		656.4	708.8	746.7	790.3	F10/F14						
	2914	3162	3208			830.5	901.2	914.3								
VGW500	85				B1											
VGW500R	1270	1350	1575	1665	A2	362	384.8	448.9	474.5	F16	F48	F60	360,000	270	330	1630
	1933	2105	2202	2328		550.9	599.9	627.6	663.5	F14/F16						
	2448	2694	2788	2948		697.7	767.8	794.6	840.2							
	3156	3410	3725	3995	899.5	971.9	1061.6	1138.6	F14							
	4399	4642	5153	5370	1254	1323	1468.6	1530.5								
VGW600	68				B1											
VGW600R	926	988	1073	1144	A2	263.9	381.6	305.8	326	F16/F25	F60	F90	720,000	370	400	2927
	1295	1342	1500	1556		369.1	382.5	427.5	433.5							
	1759	1900	2040	2227		501.3	641.5	581.4	634.7							
	2376	2578	2806	3008		677.2	734.7	799.7	857.3							
	3264	3552				960.2	1012									



## DIMENSIONAL DRAWINGS

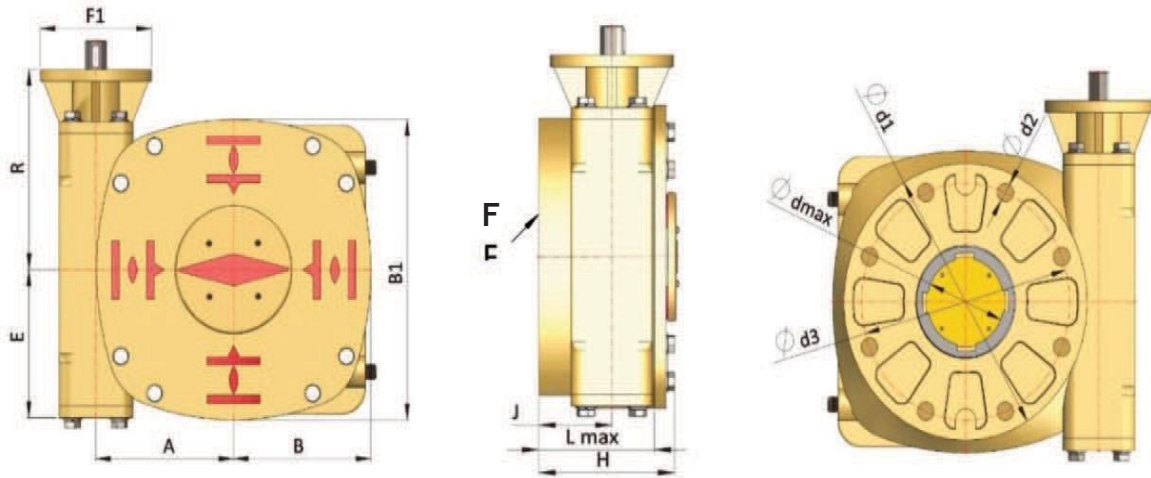

Model	EXTERNAL PART							INPUT PART			OUTPUT PART					REMARKS		
	A	B	B1	E	H	J	R	INPUT FLANGE	INPUT SHAFT		LMAX	CDMAX		d1	OUTPUT FLANGE		P.C.D	
								F1	C	KEY		MAX. STEM HEIGHT	STEM ACCEPTANCE WITH DS		STEM ACCEPTANCE WITHOUT DS		F2	d3
VGWM50	56	65	130	74	78	39	108	F07	16	5x5	68	28(8x7)	53	c130	F10/(F07)	c102	4-M10-12	
VGWM63	71	77	154	92.5	86	45	139	F10	20	6x6	76	42(14x9)	55	c154	F12/(F10)	c125	4-M12-15	
VGWM80	81	90	180	98	93	47	146	F10	20	6x6	83	58(18x11)	70	c180	F14/(F12)	c140	4-M16-24	
VGWM85	110	112	217	108	105	52	151	F10	20	6x6	83			c180	(F10/F12/F16)	c140	4-M16-24	
VGWM100	125	124	242	132	143	80	187	F14	30	8x7	135	75(20x12)	90	c210	F16/(F12/F14)	c165	4-M20-30	
								F10	20	6x6								
VGWM125	156	154	303	157	140	75	212	F14	30	8x7	130	85(20x12)	100	c300	F25(F16/F20)	c254	8-M16-24	
								F16	30	8x7								
VGWM160	205	195	386	210	162	88	278	F16	30	8x7	150	95(25x14)	130	c350	F30(F20/F25)	c298	8-M20-30	
								F14	30	8x7								
VGWM195/200	235	234	460	255	178	90	345	F16	40	12x8	165	120(28x16)	160	c415	F30(F20/F25/F35)	c298	8-M20-30	
								F25	40	12x8								
VGWM250	264	262	520	255	223	125	345	F25	40	12x8	210	155(35x20)	180	c475	F40/(F25/F30/F35)	c406	8-M36-54	
								F16	40	12x8								

Note 1: the output flange in brackets is non-standard and optional, and is not recommended generally



## DIMENSIONAL DRAWINGS

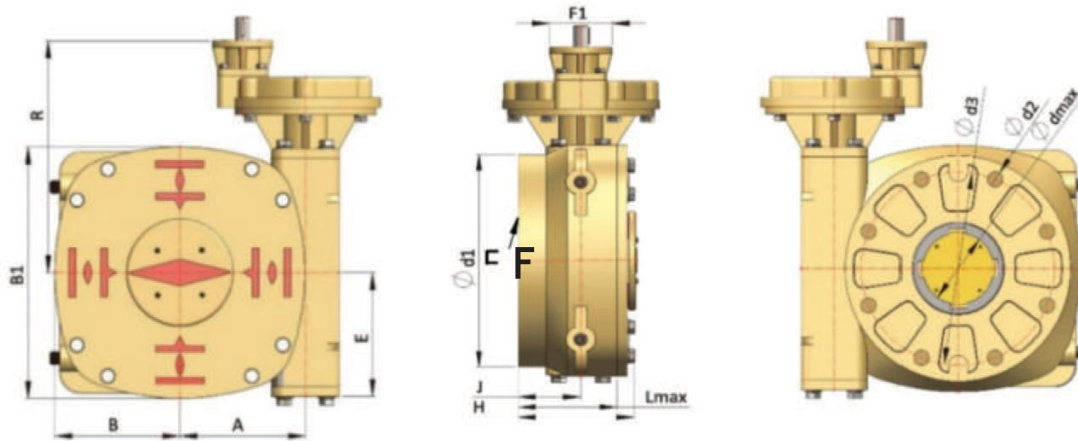

Model	EXTERNAL PART							INPUT PART			OUTPUT PART					REMARKS		
	A	B	B1	E	H	J	R	INPUT FLANGE	INPUT SHAFT		LMAX	CDMAX		d1	OUTPUT FLANGE		P.C.D	
								F1	C	KEY		MAX. STEM HEIGHT	STEM ACCEPTANCE WITH DS		STEM ACCEPTANCE WITHOUT DS		F2	d3
VGWM85R	110	112	217	108	105	52	289	F10	20	6x6	83	58(18x11)	70	c180	F14(F10/F12/F16)	c140	4-M16-24	
VGWM100R	125	124	235	132	146	80	320	F10	20	6x6	135	75(20x12)	90	c210	F16/(F12/F14)	c165	4-M20-30	
								F14	30	8x7								
VGWM125R	156	154	303	157	140	75	345	F10	20	6x6	130	85(20x12)	100	c300	F25(F16/F20)	c254	8-M16-24	
								F14	30	8x7								
VGWM160R	205	195	386	210	162	88	417	F14	30	8x7	150	95(25x14)	130	c350	F30(F20/F25)	c298	8-M20-30	
								F16	40	12x8								
VGWM195/200	235	234	460	255	178	90	480	F16	40	12x8	165	120(28x16)	160	c415	F30(F20/F25/F35)	c298	8-M20-30	
								F25	50	14x9					200			F40
VGWM250R	264	262	520	255	223	125	480	F25	50	14x9	210	155(36x20)	180	c475	F40/(F25/F30/F35)	c406	8-M36-54	
								F16	40	12x8					F48			
VGWM255R	264	262	520	255	223	125	480	F25	50	14x9	210	155(36x20)	180	c475	F40/(F25/F30/F35)	c406	8-M36-54	
								F16	40	12x8					F48			
VGWM310R	354	342	678	328	275	149	695	F14	30	8x7	260	200(45x25)	230	c560	F40/(F35/F48)	c406	8-M36-54	
								F16	40	12x8								
VGWM315R	354	342	678	328	275	149	695	F14	30	8x7	260	200(45x25)	230	c560	F40/(F35/F48)	c406	8-M36-54	
								F16	40	12x8								
VGWM400R	406	405	815	400	324	169	760	F16	40	12x8	300	220(50x28)	255	c560	F40/(F48)	c406	8-M36-54	
								F25	50	14x9					358			F60
VGWM450R	406	405	815	400	324	169	760	F16	40	12x8	300	220(50x28)	255	c560	F40/(F48)	c406	8-M36-54	
								F25	50	14x9					358			F60
VGWM500R	485	500	1000	480	345	185	846	F16	40	12x8	330	250(56x32)	280	c686	F40/(F48)	c483	12-M36-54	
								F25	50	14x9					F80			
VGWM00R	565	532	1065	583	418	218	1060	F25	50	14x9	400	300(70x36)	370	c910	F60	c603	20-M36-54	
								F30							F80			

Note 1: the output flange in brackets is non-standard and optional, and is not recommended generally. Note 2: the data marked in red shall be further confirmed according to gear ratio.

**CONTACT US**

**Valve Gears**

Unit 5 Windsor Court  
Crown Farm Industrial  
Estate  
Forest Town  
Nottinghamshire  
NG19 0FN

[sales@valve-kits.co.uk](mailto:sales@valve-kits.co.uk)

+44 (0)1623 440 211

